

5-V Low-Drop Voltage Regulator

TLE 4267

Bipolar IC

Features

- Output voltage tolerance $\leq \pm 2\%$
- Low-drop voltage
- Very low standby current consumption
- Input voltage up to 40 V
- Overvoltage protection up to 60 V (≤ 400 ms)
- Reset function down to 1 V output voltage
- ESD protection up to 2000 V
- Adjustable reset time
- On/off logic
- Overtemperature protection
- Reverse polarity protection
- Short-circuit proof
- Wide temperature range
- Suitable for use in automotive electronics

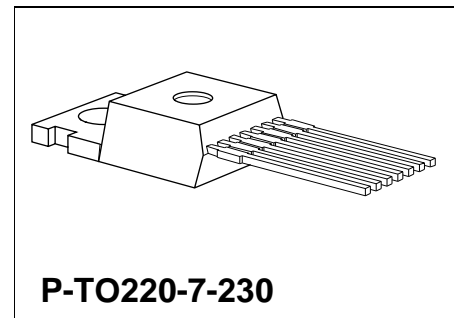
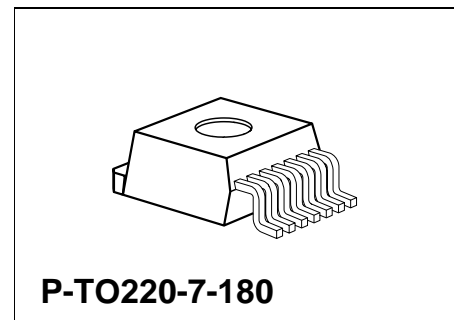
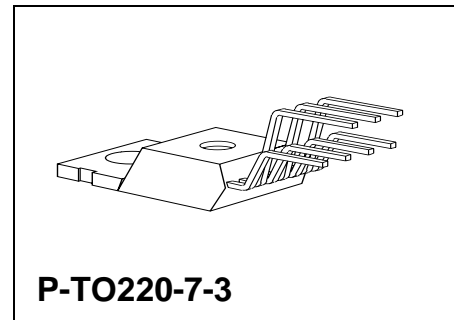

Type	Ordering Code	Package
TLE 4267	Q67000-A9153	P-TO220-7-3
TLE 4267 G	Q67006-A9169	P-TO220-7-180 (SMD)
TLE 4267 S	Q67000-A9246	P-TO220-7-230

Functional Description

TLE 4267 is a 5-V low-drop voltage regulator in a TO220-7 package. It supplies an output current of > 400 mA. The IC is shortcircuit-proof and incorporates temperature protection that disables the IC at overtemperature.

Application

The IC regulates an input voltage V_I in the range $5.5\text{ V} < V_I < 40\text{ V}$ to $V_{Q_{rated}} = 5.0\text{ V}$. A reset signal is generated for an output voltage V_Q of $< 4.5\text{ V}$. The reset delay can be set with an external capacitor. The device has two logic inputs. It is turned-ON by a voltage of $> 4\text{ V}$ on E2 by the ignition for example. It remains active as a function of the voltage on E6, even if the voltage on E2 goes Low. This makes it possible to implement a self-holding circuit without external components. When the device is turned-OFF, the output voltage drops to 0 V and current consumption tends towards 0 μA .

Design Notes for External Components

The input capacitor C_1 is necessary for compensation line influences. The resonant circuit consisting of lead inductance and input capacitance can be damped by a resistor of approx. 1Ω in series with C_1 . The output capacitor is necessary for the stability of the regulating circuit. Stability is guaranteed at values of $\geq 22 \mu\text{F}$ and an ESR of $\leq 3 \Omega$ within the operating temperature range.

Circuit Description

The control amplifier compares a reference voltage, which is kept highly accurate by resistance adjustment, to a voltage that is proportional to the output voltage and drives the base of the series transistor via a buffer. Saturation control as a function of the load current prevents any over-saturating of the power element.

A comparator in the reset-generator block compares a reference that is independent of the input voltage to the scaled-down output voltage. If this reaches a value of 4.5 V , the reset-delay capacitor is discharged and then the reset output is set Low. As the output voltage increases again, the reset-delay capacitor is charged with constant current from $V_Q = 4.5 \text{ V}$ onwards. When the capacitor voltage reaches the upper switching threshold, reset goes High again. The reset delay can be set within wide range by selection of the external capacitor.

With the integrated turn-ON/turn-OFF logic it is simple to implement delayed turn-OFF without external components.

Truth Table for Turn-ON/Turn-OFF Logic

Pin 2	Pin 6	V_Q	Remarks
L	X	OFF	Initial state, pin 6 internally pulled up
H	X	ON	Regulator switched on via pin 2, by ignition for example
H	L	ON	Pin 6 clamped active to ground by controller while pin 2 is still high
X	L	ON	Previous state remains, even ignition is shut off: self-holding state
L	L	ON	Ignition shut off while regulator is in self-holding state
L	H	OFF	Regulator shut down by releasing of pin 6 while pin 2 remains Low, final state. No active clamping required by external self-holding circuit (μC) to keep regulator shut off.

Pin 2: (Inhibit, E2) Enable function, active High

Pin 6: (Hold, E6) Hold and release function, active Low

Pin Configuration

(top view)

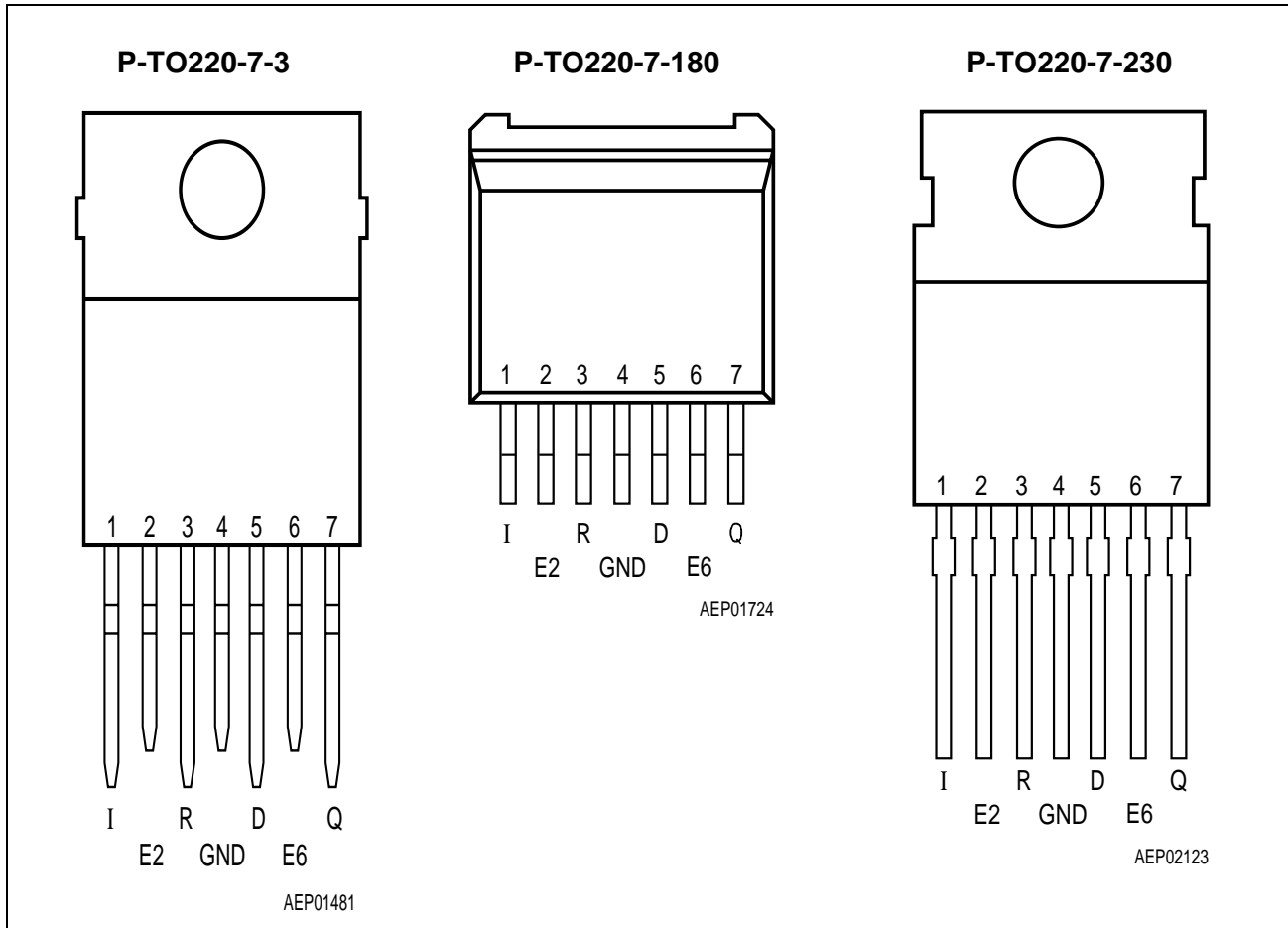

Pin Definitions and Functions

Pin	Symbol	Function
1	I	Input; block to ground directly at the IC by a ceramic capacitor
2	E2	Inhibit; device is turned-ON by High signal on this pin; internal pulldown resistor of 100 kΩ
3	R	Reset Output; open-collector output internally connected to the output via a resistor of 30 kΩ
4	GND	Ground; connected to rear of chip
5	D	Reset Delay; connect with capacitor to GND for setting delay
6	E6	Hold; see truth table above for function; this input is connected to output voltage across pullup resistor of 50 kΩ
7	Q	5-V Output; block to GND with 22-μF capacitor, ESR < 3 Ω

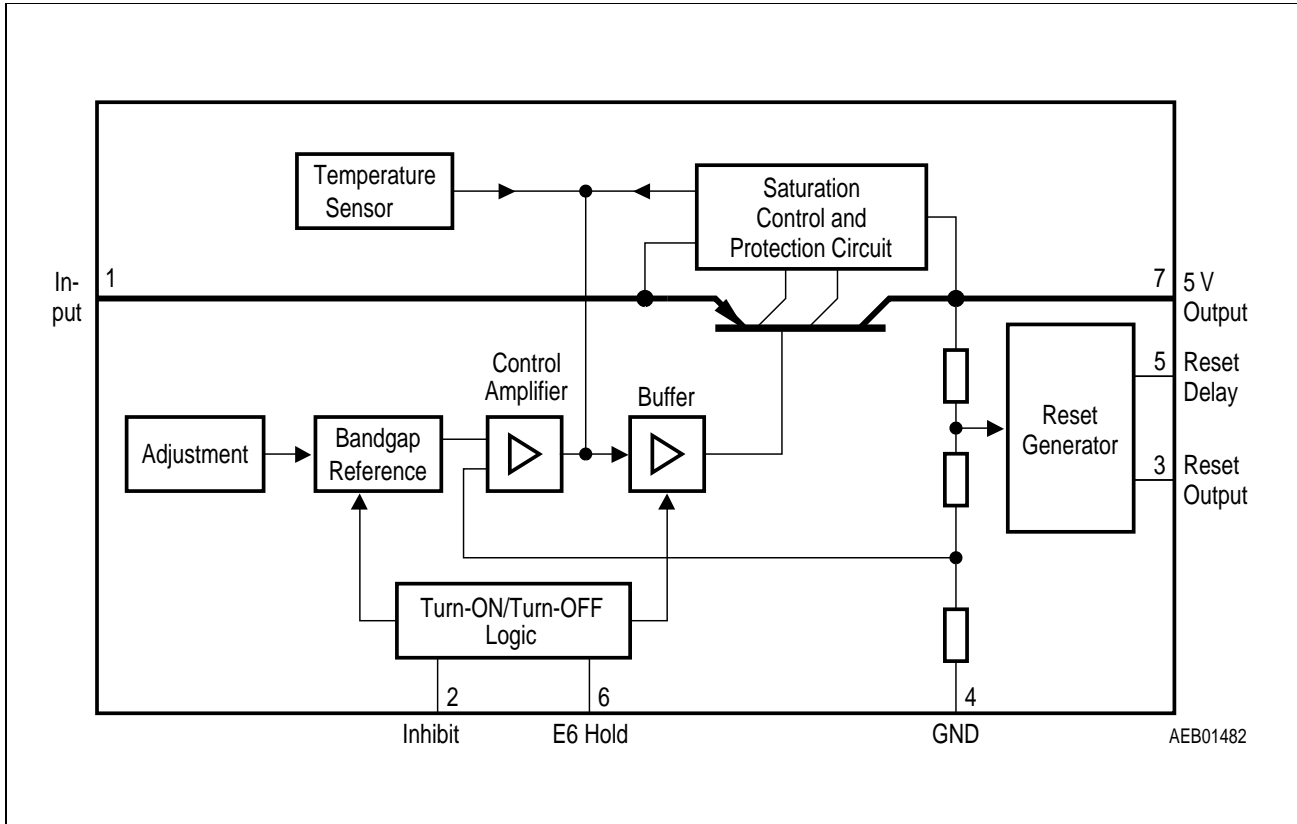

Block Diagram

Absolute Maximum Ratings

$T_J = -40$ to 150 °C

Parameter	Symbol	Limit Values		Unit	Notes
		min.	max.		

Input

Voltage	V_I	- 42	42	V	-
Voltage	V_I	-	60	V	$t \leq 400$ ms
Current	I_I	-	-	-	Limited internally

Reset Output

Voltage	V_R	- 0.3	7	V	-
Current	I_R	-	-	-	Limited internally

Reset Delay

Voltage	V_d	- 0.3	42	V	-
---------	-------	-------	----	---	---

Absolute Maximum Ratings (cont'd)

$T_J = -40$ to 150 °C

Parameter	Symbol	Limit Values		Unit	Notes
		min.	max.		
Current	I_d	–	–	–	–

Output

Voltage	V_Q	– 0.3	7	V	–
Current	I_Q	–	–	–	Limited internally

Inhibit

Voltage	V_{E2}	– 42	42	V	
Current	I_{E2}	– 5	5	mA	$t \leq 400$ ms

Hold

Voltage	V_{E6}	– 0.3	7	V	–
Current	I_{E6}	–	–	mA	Limited internally

GND

Current	I_{GND}	– 0.5	–	A	–
---------	-----------	-------	---	---	---

Temperatures

Junction temperature	T_J	–	150	°C	–
Storage temperature	T_{stg}	– 50	150	°C	–

Operating Range

Parameter	Symbol	Limit Values		Unit	Notes
		min.	max.		
Input voltage	V_I	5.5	40	V	see diagram
Junction temperature	T_J	– 40	150	°C	–

Thermal Resistance

Junction ambient	R_{thja}	–	70	K/W	–
Junction-case	R_{thjc}	–	6	K/W	–
Junction-case	R_{thjc}	–	2	K/W	$t < 1$ ms

Characteristics

$V_I = 13.5 \text{ V}$; $-40 \text{ }^\circ\text{C} < T_J < 125 \text{ }^\circ\text{C}$; $V_{E2} > 4 \text{ V}$ (unless specified otherwise)

Parameter	Symbol	Limit Values			Unit	Test Condition
		min.	typ.	max.		
Output voltage	V_Q	4.9	5	5.1	V	$5 \text{ mA} \leq I_Q \leq 400 \text{ mA}$ $6 \text{ V} \leq V_I \leq 26 \text{ V}$
Output voltage	V_Q	4.9	5	5.1	V	$5 \text{ mA} \leq I_Q \leq 150 \text{ mA}$ $6 \text{ V} \leq V_I \leq 40 \text{ V}$
Output-current limiting	I_Q	500	–	–	mA	$T_J = 25 \text{ }^\circ\text{C}$
Current consumption $I_q = I_I - I_Q$	I_q	–	–	50	μA	Regulator-OFF
Current consumption $I_q = I_I - I_Q$	I_q	–	1.0	10	μA	$T_J = 25 \text{ }^\circ\text{C}$ IC turned off
Current consumption $I_q = I_I - I_Q$	I_q	–	1.3	4	mA	$I_Q = 5 \text{ mA}$ IC turned on
Current consumption $I_q = I_I - I_Q$	I_q	–	–	60	mA	$I_Q = 400 \text{ mA}$
Current consumption $I_q = I_I - I_Q$	I_q	–	–	80	mA	$I_Q = 400 \text{ mA}$ $V_I = 5 \text{ V}$
Drop voltage	V_{Dr}	–	0.3	0.6	V	$I_Q = 400 \text{ mA}^{1)}$
Load regulation	ΔV_Q	–	–	50	mV	$5 \text{ mA} \leq I_Q \leq 400 \text{ mA}$
Supply-voltage regulation	ΔV_Q	–	15	25	mV	$V_I = 6 \text{ to } 36 \text{ V}$; $I_Q = 5 \text{ mA}$
Supply-voltage rejection	SVR	–	54	–	dB	$f_r = 100 \text{ Hz}$; $V_r = 0.5 \text{ V}_{pp}$
Longterm stability	ΔV_Q	–	0	–	mV	1000 h

1) Drop voltage = $V_I - V_Q$ (measured when the output voltage V_Q has dropped 100 mV from the nominal value obtained at $V_I = 13.5 \text{ V}$)

Characteristics (cont'd)

Parameter	Symbol	Limit Values			Unit	Test Condition
		min.	typ.	max.		

Reset Generator

Switching threshold	V_{rt}	4.2	4.5	4.8	V	–
Reset High level	–	4.5	–	–	V	$R_{ext} = \infty$
Saturation voltage	V_R	–	0.1	0.4	V	$R_R = 4.7 \text{ k}\Omega$ ¹⁾
Pullup	R_R	–	30	–	k Ω	–
Saturation voltage	$V_{D,sat}$	–	50	100	mV	$V_Q < V_{RT}$
Charge current	I_d	8	15	25	μA	$V_D = 1.5 \text{ V}$
Delay switching threshold	V_{dt}	2.6	3	3.3	V	–
Delay	t_d	–	20	–	ms	$C_d = 100 \text{ nF}$
Switching threshold	V_{st}	–	0.43	–	V	–
Delay	t_t	–	2	–	μs	$C_d = 100 \text{ nF}$

Inhibit

Turn-ON voltage	V_{E2}	–	3	4	V	IC turned-ON
Turn-OFF voltage	V_{E2}	2	–	–	V	IC turned-OFF
Pulldown	R_{E2}	50	100	200	k Ω	–
Hysteresis	ΔV_{E2}	0.2	0.5	0.8	V	–
Input current	I_{E2}	–	35	100	μA	$V_{IP2} = 4 \text{ V}$
Holding voltage	V_{E6}	30	35	40	%	Referred to V_Q
Turn-OFF voltage	V_{E6}	60	70	80	%	Referred to V_Q
Pullup	R_{E6}	20	50	100	k Ω	–

Overvoltage Protection

Turn-OFF voltage	$V_{i,ov}$	42	44	46	V	–
Turn-ON hysteresis	$\Delta V_{i,ov}$	2	–	6	V	–

1) The reset output is Low between $V_Q = 1 \text{ V}$ and V_{RT}

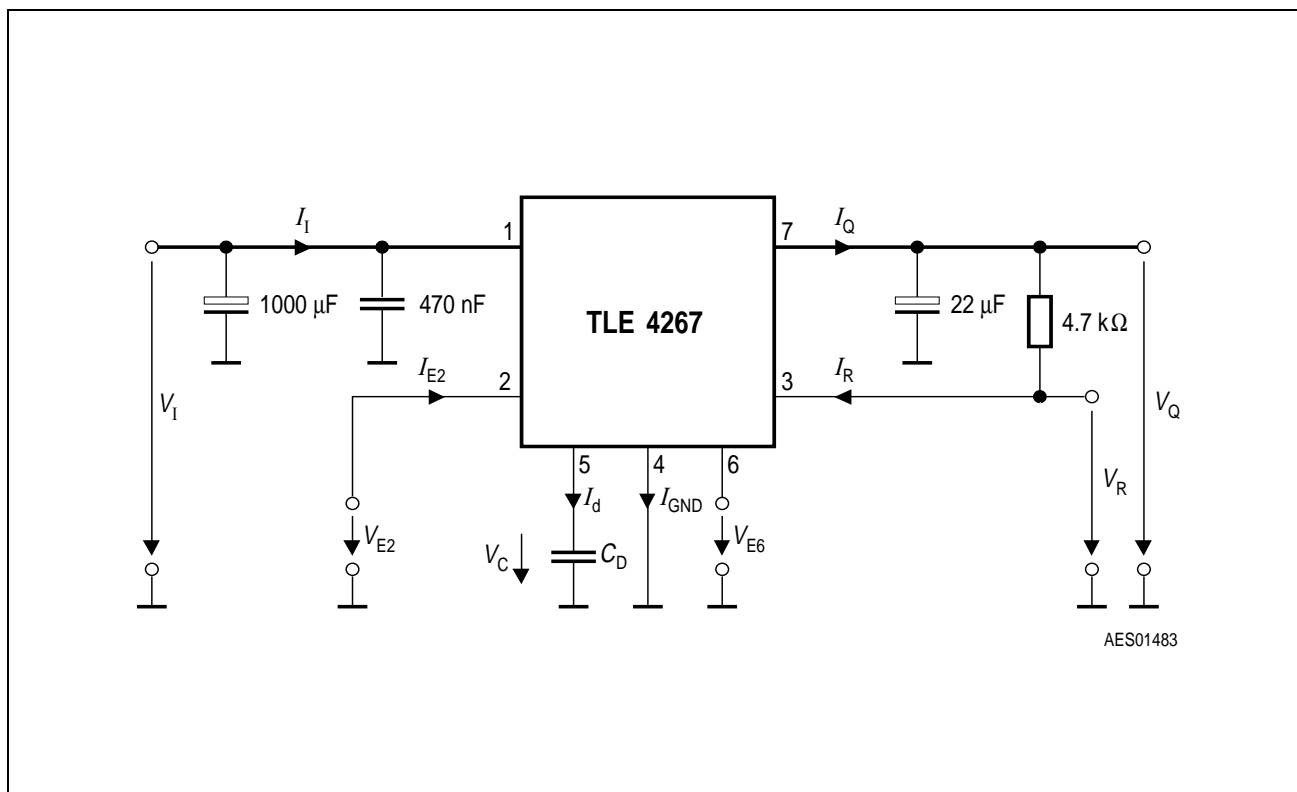

Test Circuit

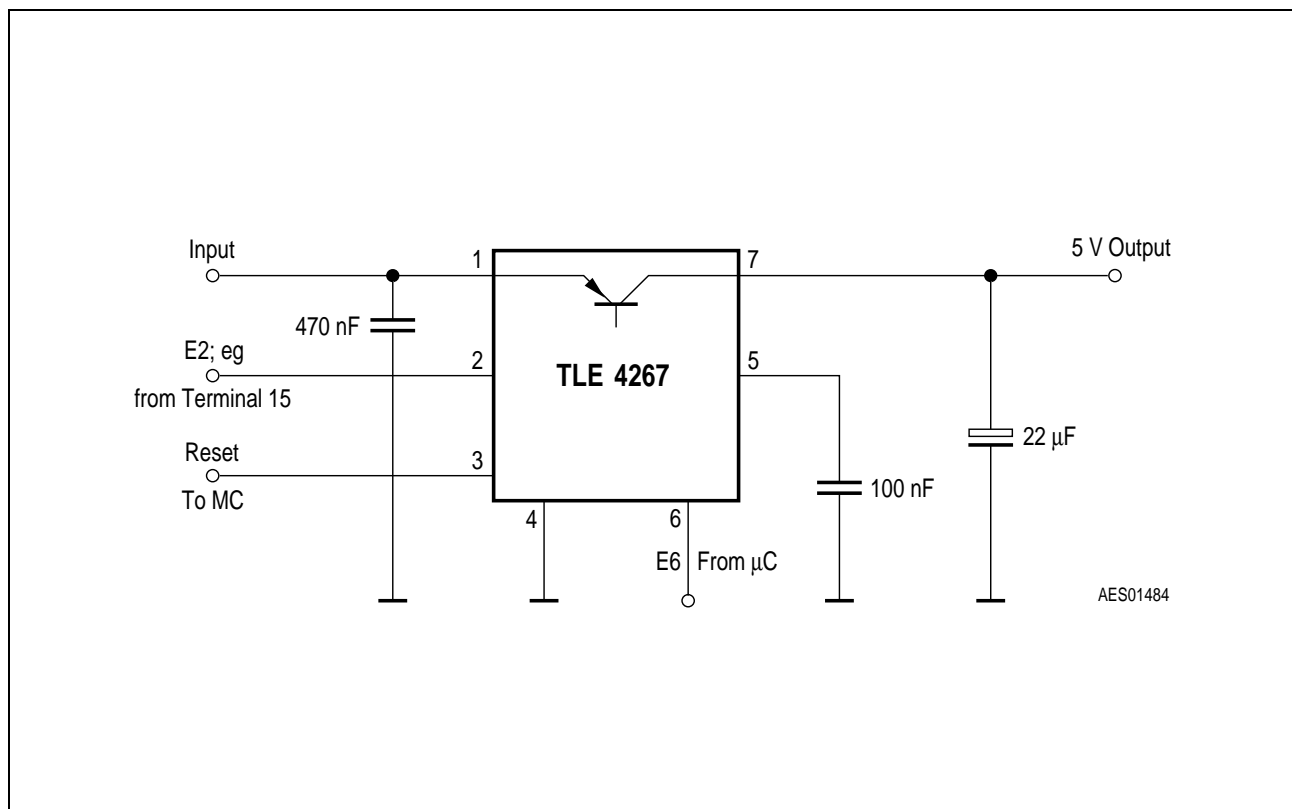

Application Circuit

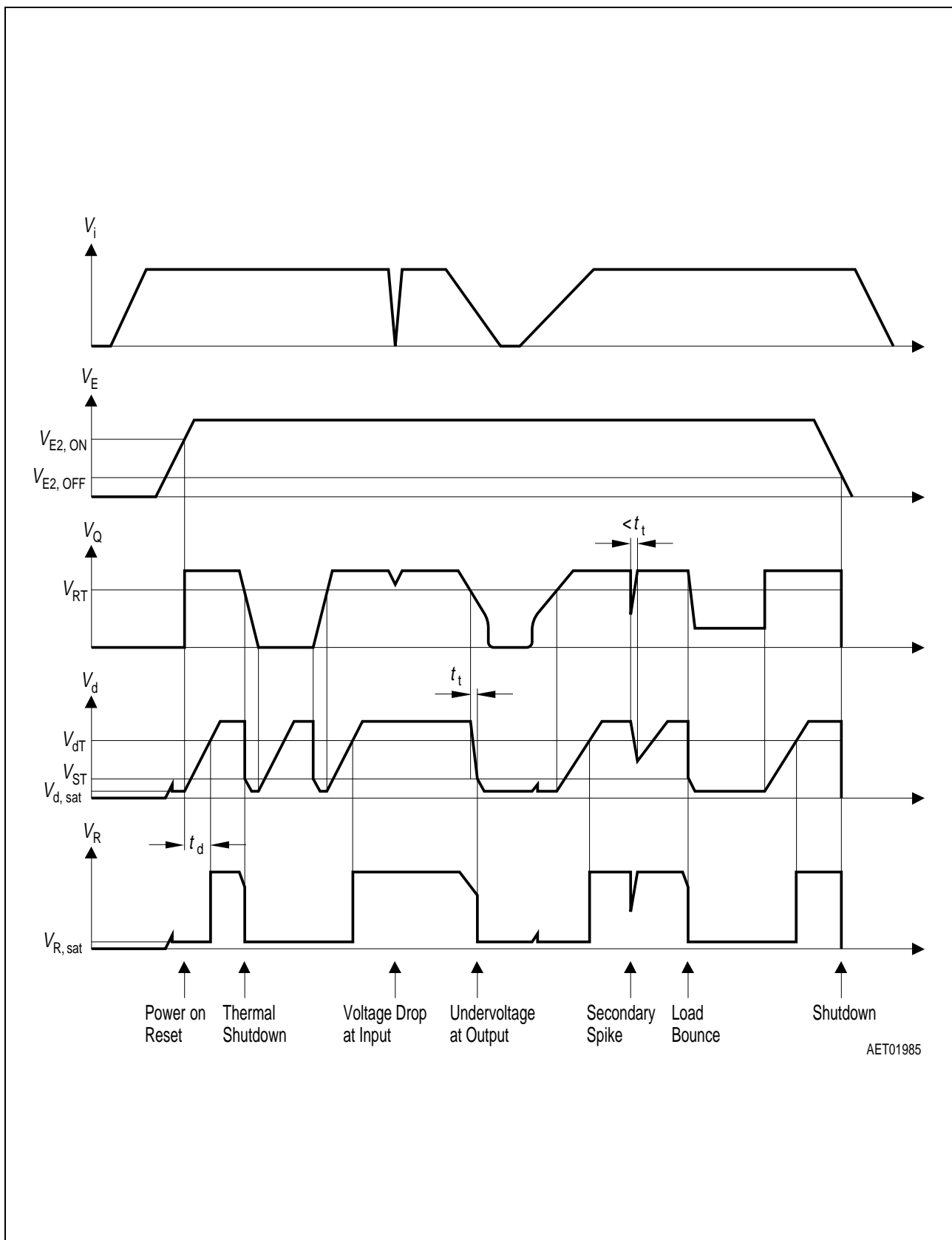

Time Response

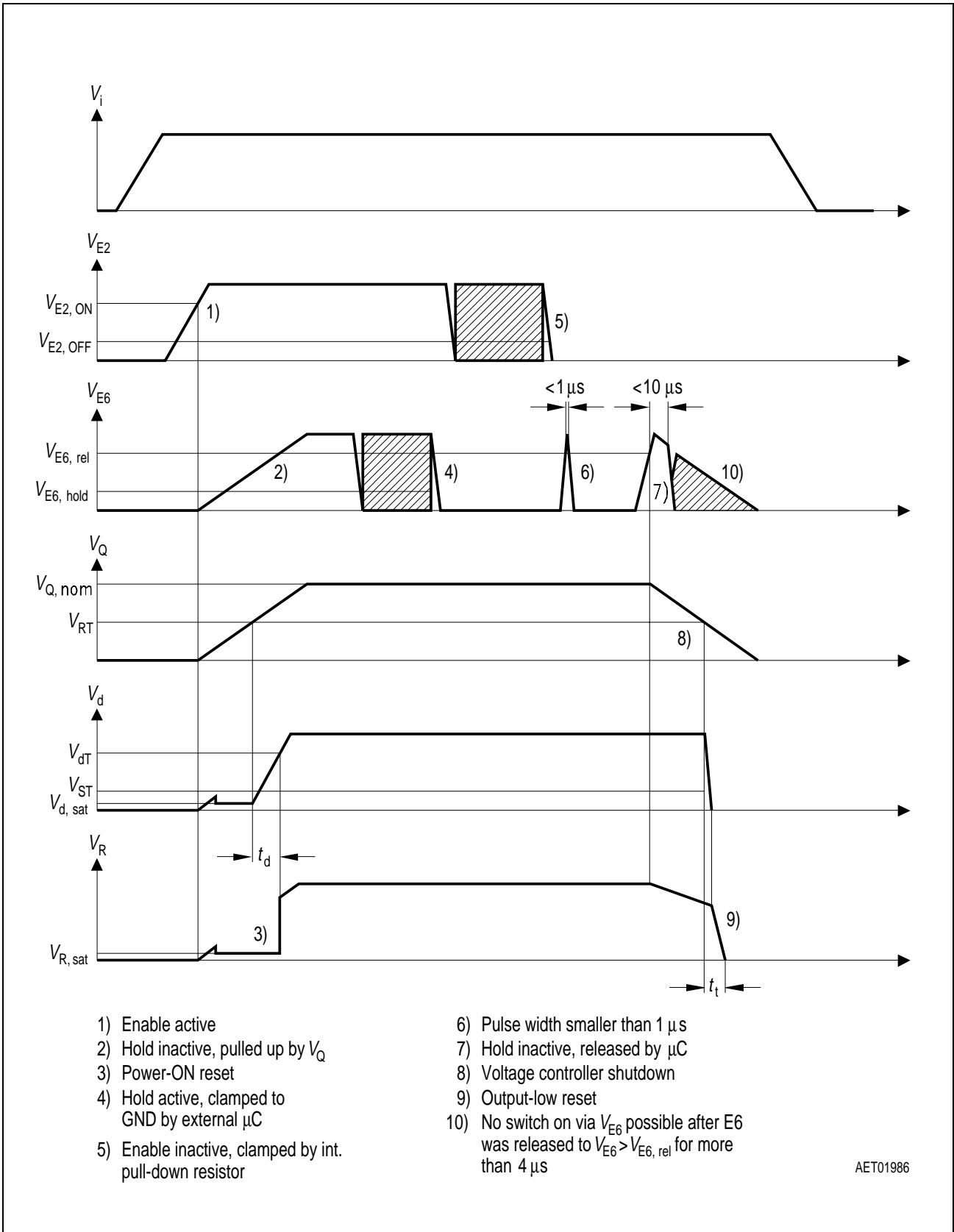

Enable and Hold Behaviour

Output Voltage V_Q versus Temperature T_j

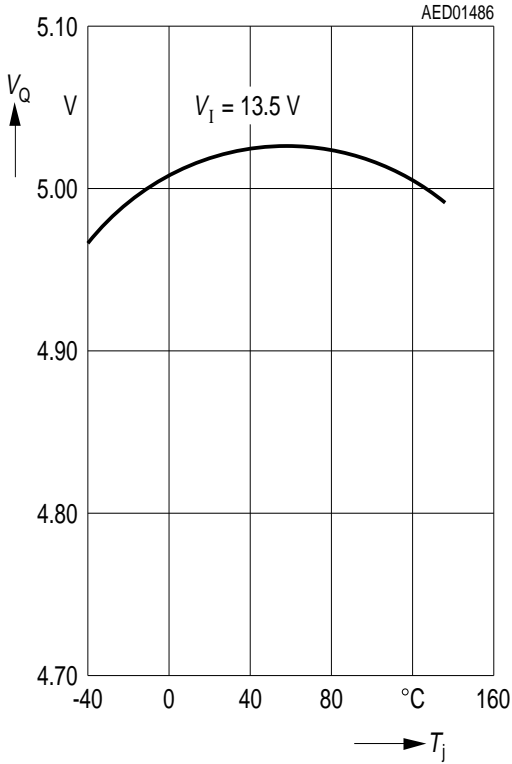

Drop Voltage V_{Dr} versus Output Current I_Q

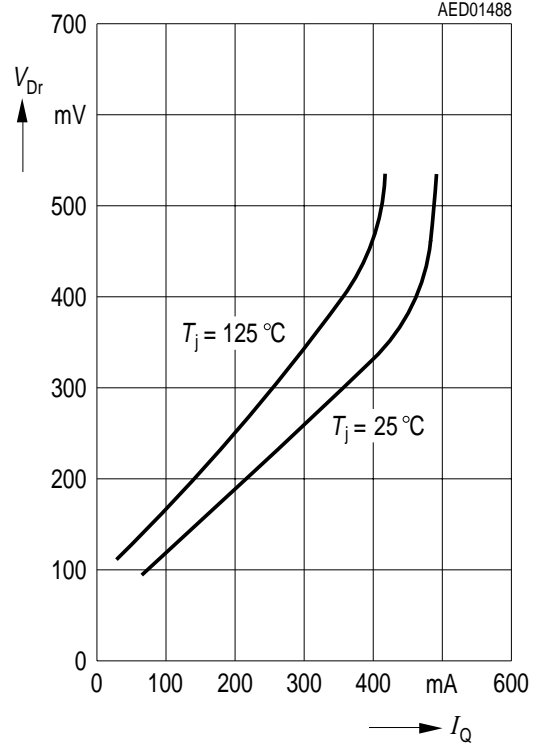

Charge Current I_d versus Temperature T_j

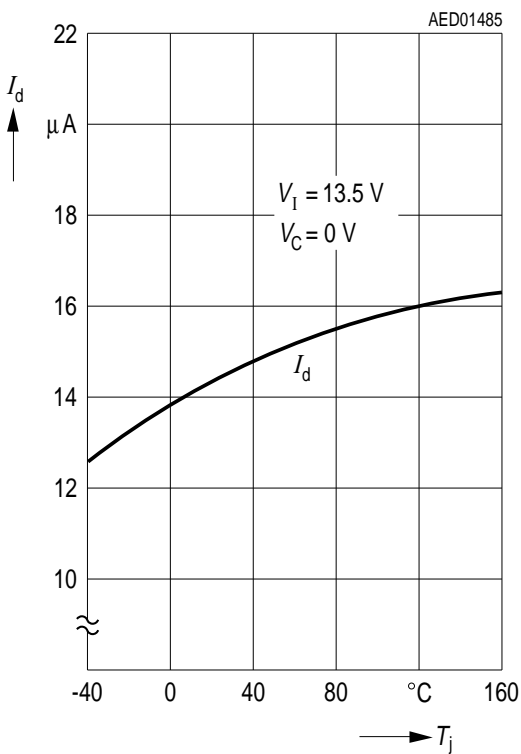

Delay Switching Threshold V_{dT} versus Temperature T_j

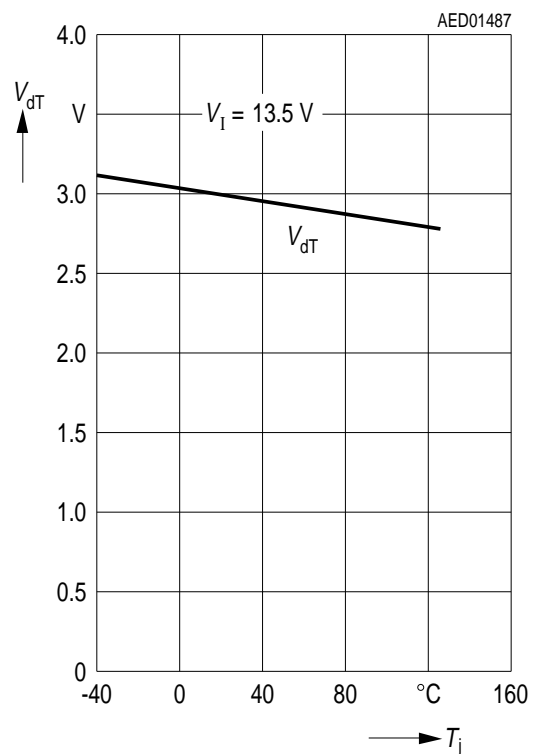

Current Consumption I_q versus Output Current I_Q

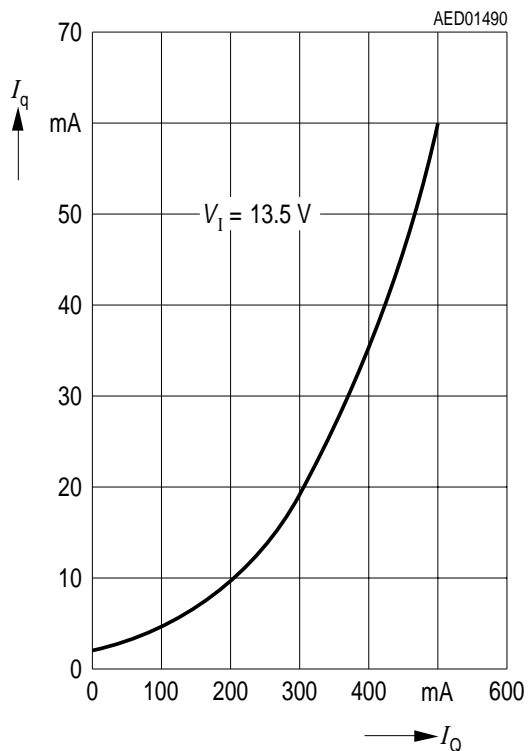

Current Consumption I_q versus Input Voltage V_i

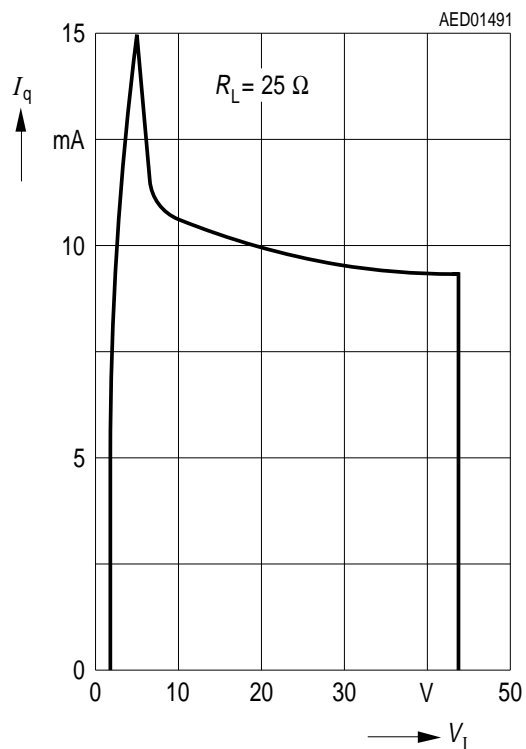

Output Current I_Q versus Temperature T_j

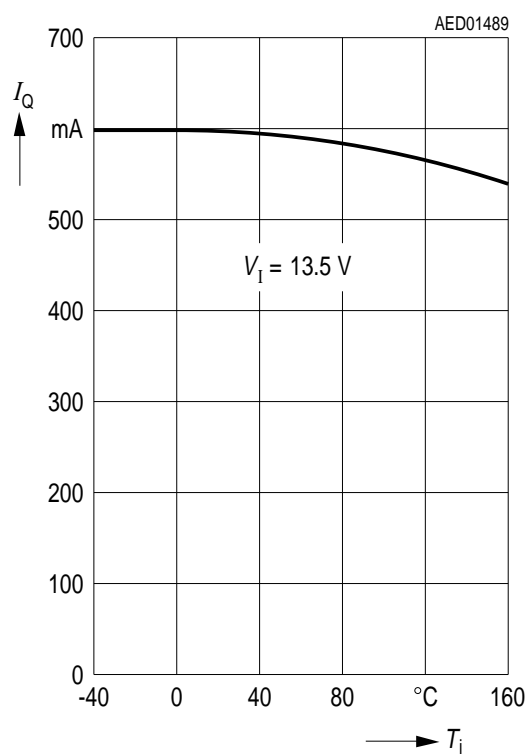

Output Current I_Q versus Input Voltage V_i

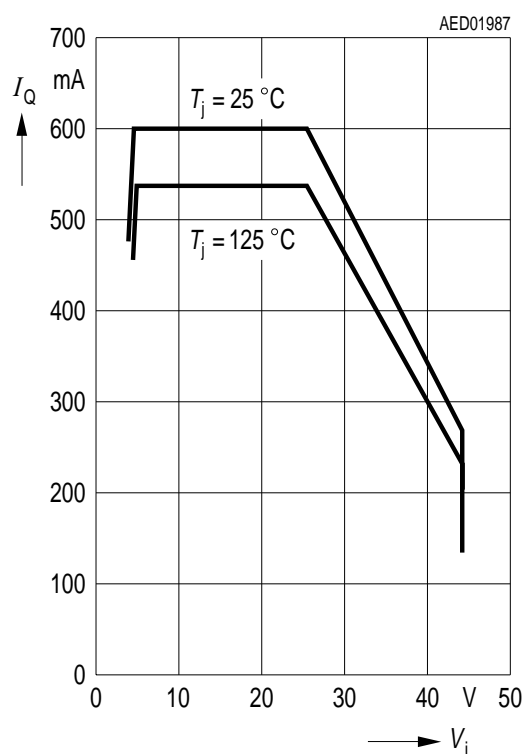

**Output Voltage V_Q versus
Inhibit Voltage V_{E2}**

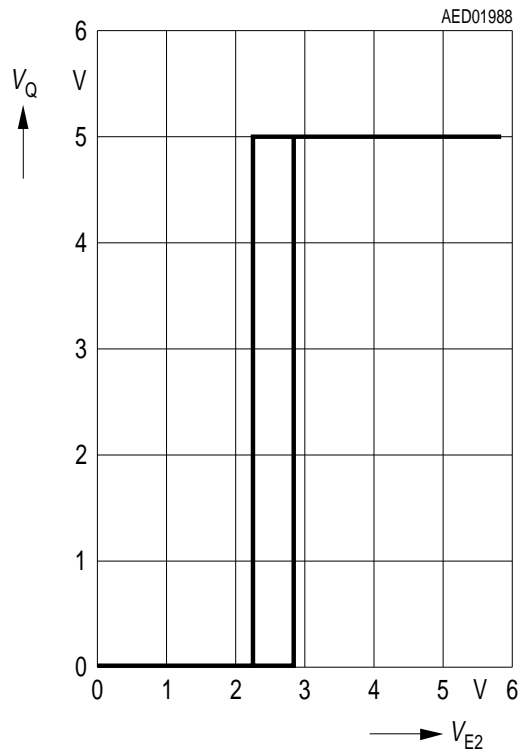

**Inhibit Current I_{E2} versus
Inhibit Voltage V_{E2}**

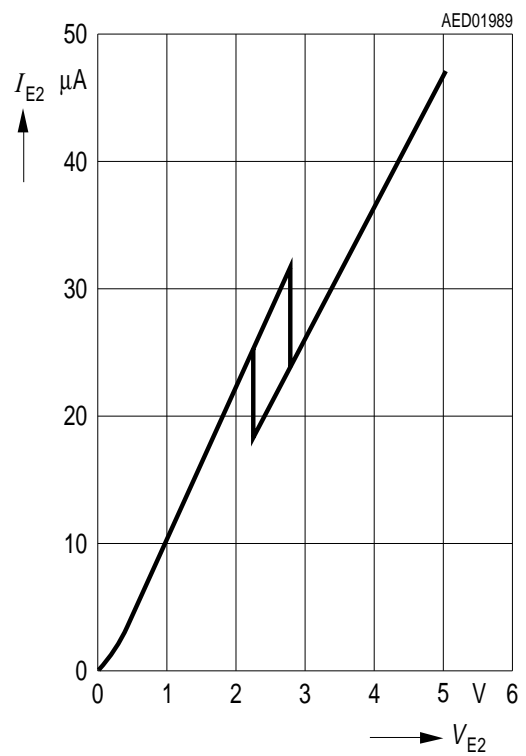

Package Outlines

P-TO220-7-3 (Plastic Transistor Single Outline)

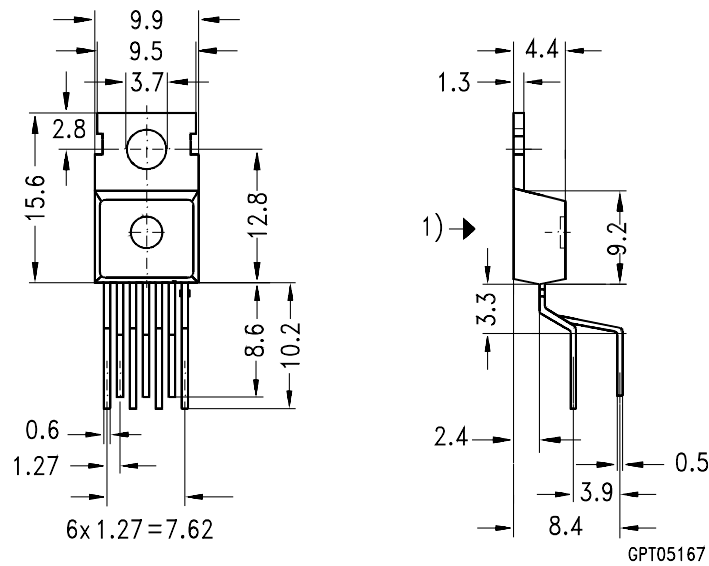

1) shear and punch direction no burrs this surface

Sorts of Packing

Package outlines for tubes, trays etc. are contained in our Data Book "Package Information"

Dimensions in mm

P-TO220-7-180
(Plastic Transistor Single Outline)

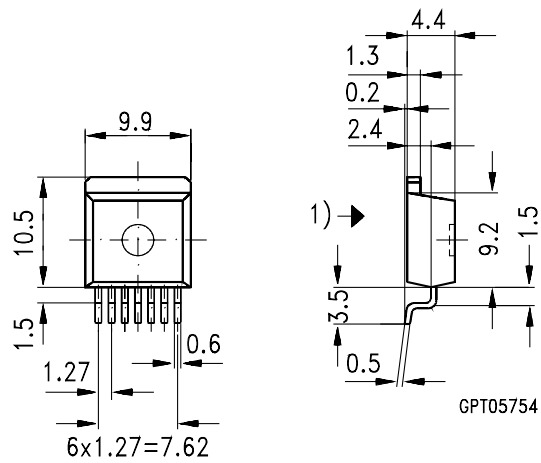

1) shear and punch direction no burrs this surface

Sorts of Packing

Package outlines for tubes, trays etc. are contained in our Data Book "Package Information"

SMD = Surface Mounted Device

Dimensions in mm

P-TO220-7-230

(Plastic Transistor Single Outline)

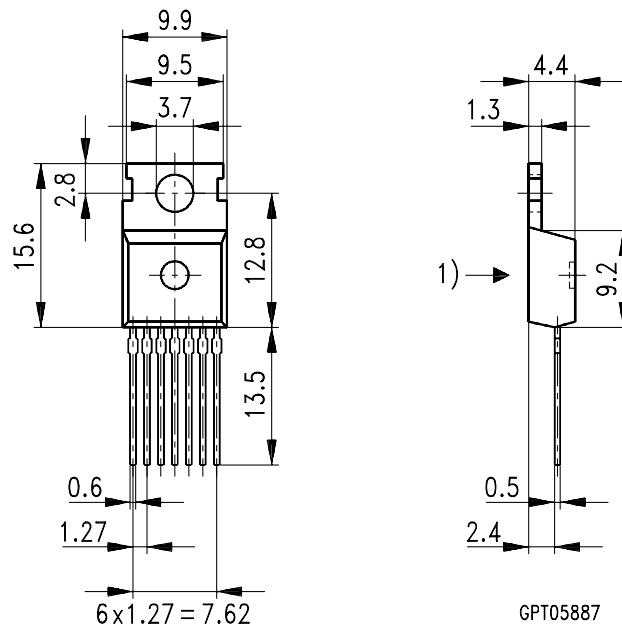

1) Shear and punch direction no burrs this surface

Sorts of Packing

Package outlines for tubes, trays etc. are contained in our Data Book "Package Information"

Dimensions in mm

This datasheet has been downloaded from:

www.DatasheetCatalog.com

Datasheets for electronic components.